

A22060



Ø220x60mm
(Ø8.60"x2.36")



HOUSING
IMPELLER
BEARING
MOTOR TYPE
TERMINATION
OPERATING VOLTAGE RANGE

DIELECTRIC STRENGTH
INSULATION
INSULATION RESISTANCE
OPERATING TEMPERATURE
SAFETY
WEIGHT
ROHS COMPLIANCE

Aluminum Die Casting, Painted Black
Thermoplastic PBT, UL94V-0
Ball
Shaded Pole Motor
Lead Wire
85VAC to 125VAC for 115V Type
185VAC to 245VAC for 230V Type
1,500VAC for 1 second
Class A
10M Ohms Min. @500 VDC
-10°C to +70°C
Impedance Protected
1400g
Yes

DIMENSION

ROTATION DIRECTION

AIR FLOW

Mounting Panel Cutout
Outlet Side & Inlet Side

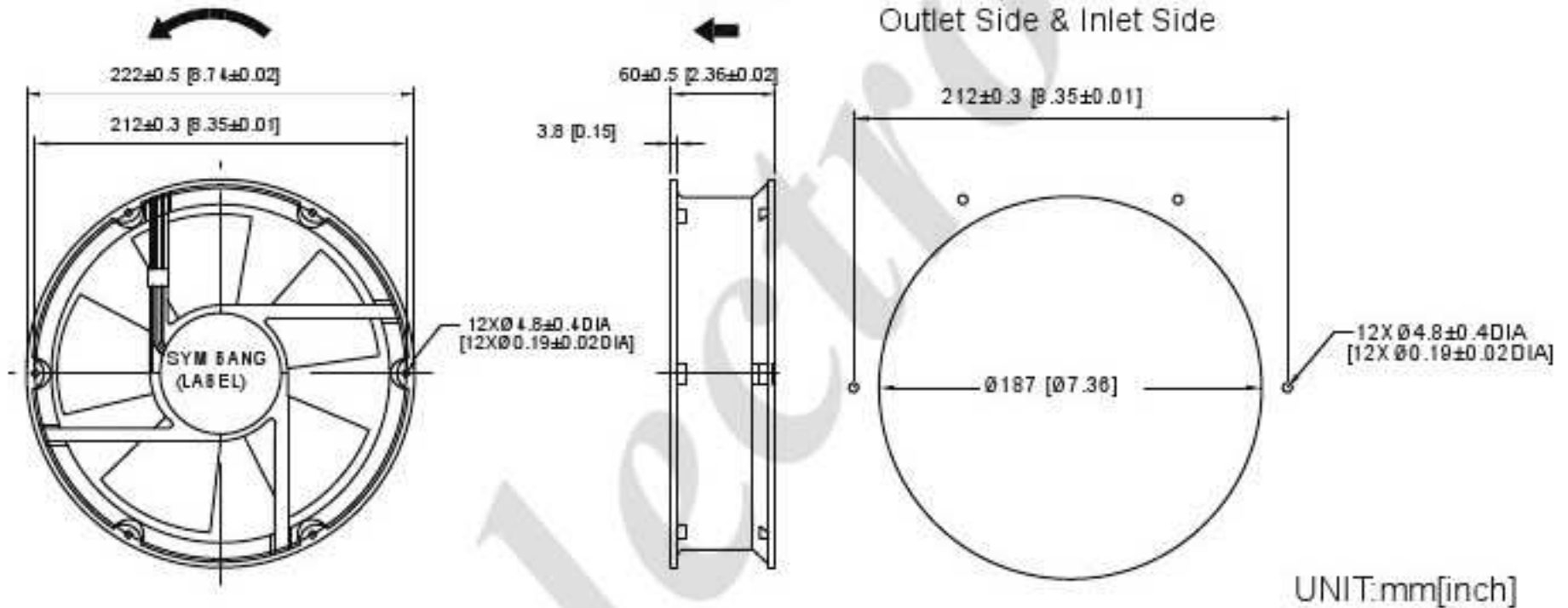

SPECIFICATION

MODEL NO	RATED VOLTAGE (V)	FREQUENCY (Hz)	RATED CURRENT (A)	INPUT POWER (W)	SPEED (RPM)	MAX. AIR PRESSURE		MAX. AIR FLOW		NOISE dB(A) @ 1M
						inchH ₂ O	mmH ₂ O	CFM	m ³ /min	
A22060V1H	115	50/60	0.60/0.60	40/40	2600/2200	0.22/0.11	5.5/2.8	360/340	10.19/9.62	56
A22060V2H	230	50/60	0.35/0.32	44/44	2600/2700	0.22/0.11	5.5/2.8	360/340	10.19/9.62	56

AIR PERFORMANCE

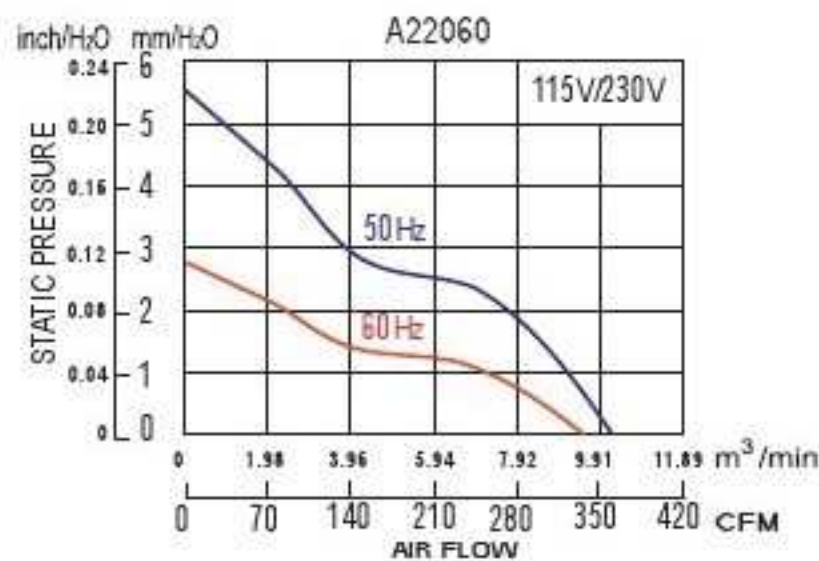

A22060-B



Ø220x60mm
(Ø8.66"x2.36")



HOUSING	Aluminum Die Casting, Painted Black
IMPELLER	Thermoplastic PBT, UL94V-0
BEARING	Ball
MOTOR TYPE	Capacitor Motor
TERMINATION	Terminal Lead Wires
OPERATING VOLTAGE RANGE	100VAC to 125VAC for 110V Type 200VAC to 240VAC for 220V Type
DIELECTRIC STRENGTH	1,500VAC for 1 minute
INSULATION	Class A
INSULATION RESISTANCE	10M Ohms Min. @500 VDC
OPERATING TEMPERATURE	-10°C to +70°C
SAFETY	Thermally Protected
WEIGHT	1600g
ROHS COMPLIANCE	Yes

DIMENSION

ROTATION DIRECTION

AIR FLOW

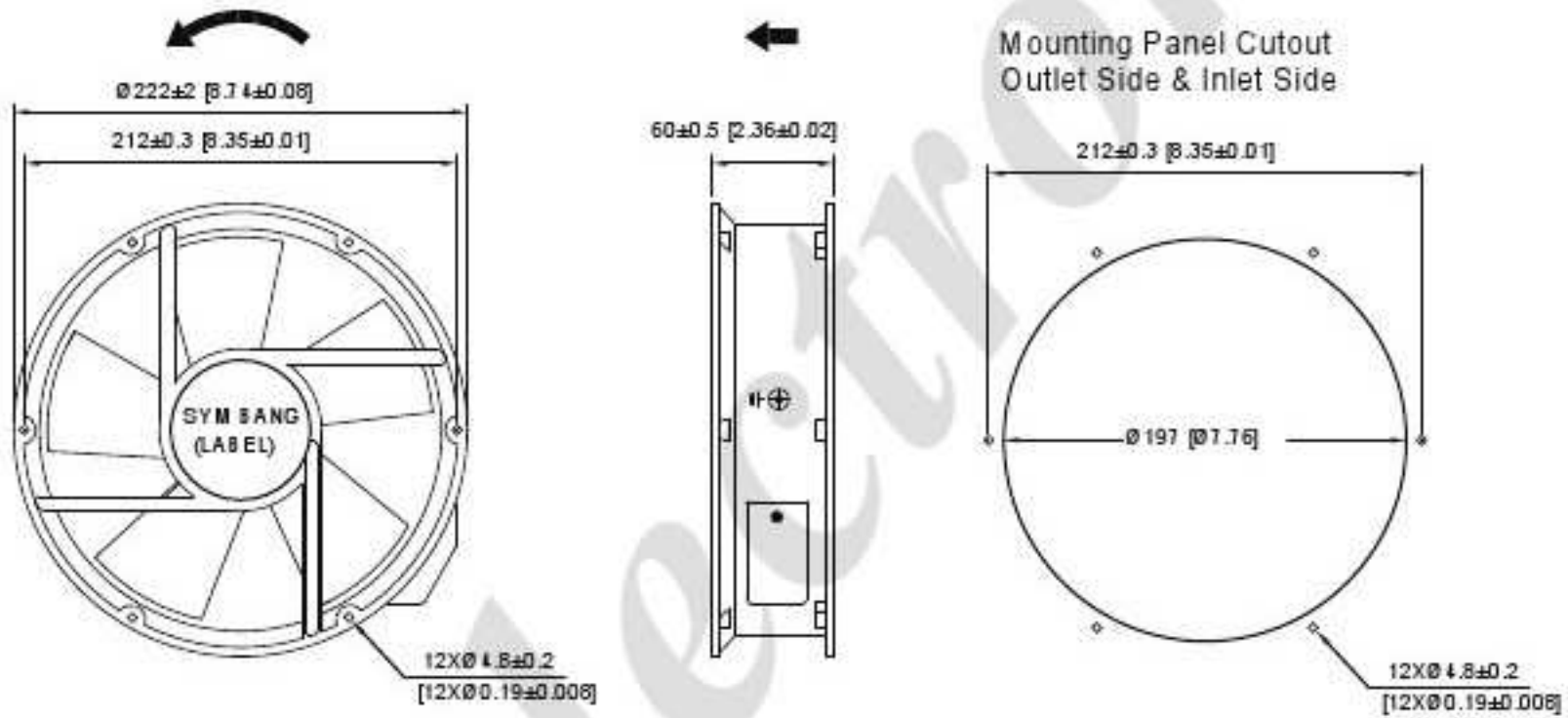

UNIT:mm[inch]

SPECIFICATION

MODEL NO.	RATED VOLTAGE (V)	FREQUENCY (Hz)	RATED CURRENT (A)	INPUT POWER (W)	SPEED (RPM)	MAX. AIR PRESSURE		MAX. AIR FLOW		NOISE dB(A) @1M
						inchH ₂ O	mmH ₂ O	CFM	m ³ /min	
A22060V1HB-B	110	50/60	0.42	42	2600/2900	0.83/0.95	21/24	406/465	11.5/13.2	62/68
A22060V2HB-B	220	50/60	0.20	40	2600/2900	0.83/0.95	21/24	406/465	11.5/13.2	62/68

AIR PERFORMANCE

